

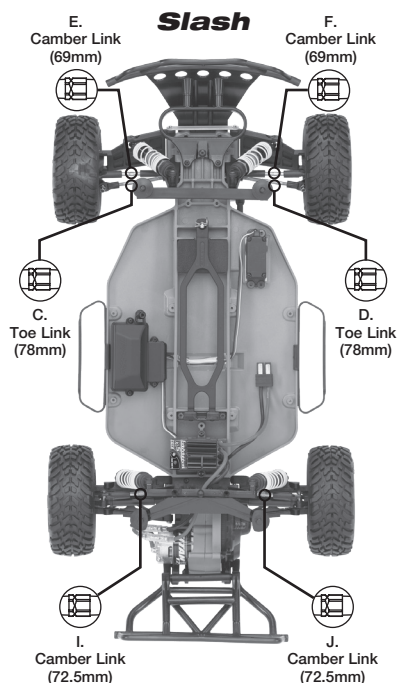

## Turnbuckle Instructions

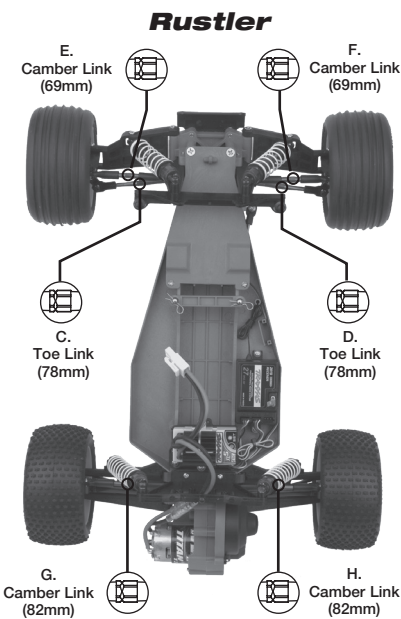
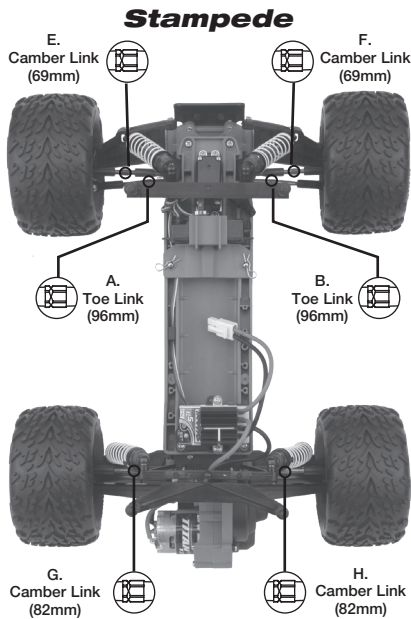

2336X / 2336A / 5595

3139X / 3139A

3738A / 3738 / 3737A / 3737

3741X / 3741A / 3737 / 3737A / 3738 / 3738A

### A. Left Toe Link - Stampede (actual size)

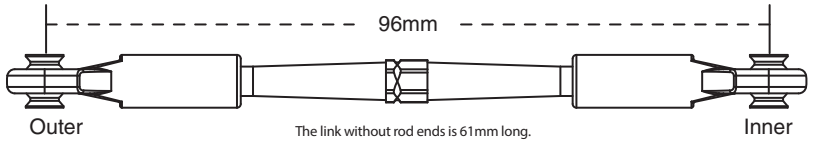

### B. Right Toe Link - Stampede (actual size)

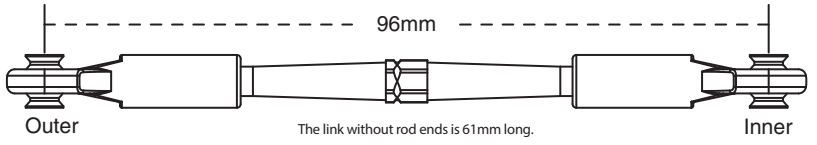

### C. Left Toe Link - Rustler & Slash (actual size)

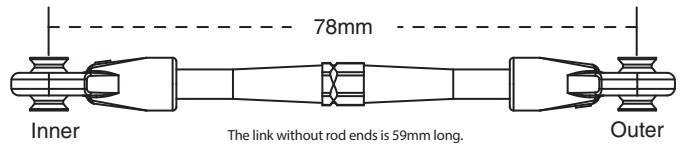

### D. Right Toe Link - Rustler & Slash (actual size)

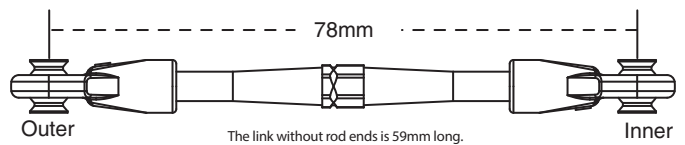

### E. Front Left Camber Link - Rustler, Stampede, & Slash (actual size)

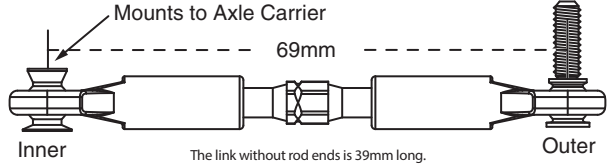

### F. Front Right Camber Link - Rustler, Stampede, & Slash (actual size)

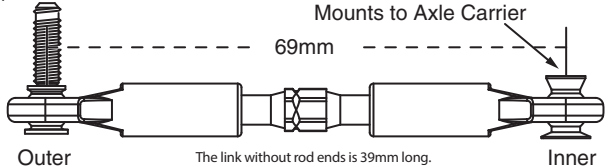

### G. Rear Left Camber Link - Rustler & Stampede (actual size)

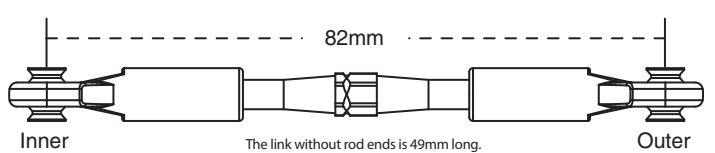

### H. Rear Right Camber Link - Rustler & Stampede (actual size)

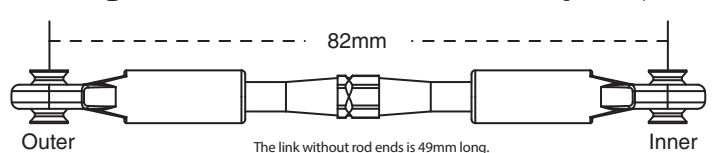

### I. Rear Left Camber Link - Slash (actual size)

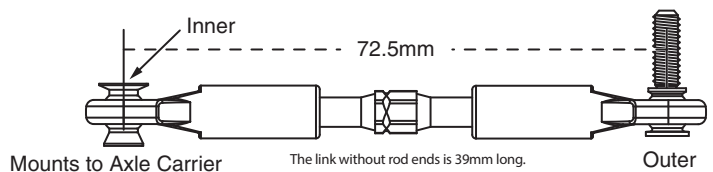

### J. Rear Right Camber Link - Slash (actual size)

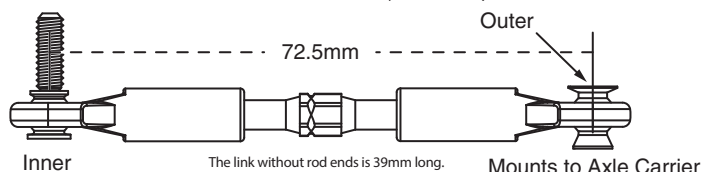

### Left Hand Thread Indicators

All of the turnbuckles on the truck should be installed so the left hand thread indicators point to the same direction. This makes it easier to remember which way to turn the wrench to increase or decrease turnbuckle length (the direction is same at all four corners). Note that the groove in the hex indicates the side of the turnbuckle with the left-hand threads. For replacement rod ends, use part #5525 (sold separately).

